

Sheet: Oscillators

File: oscillators.sch

Sheet: VFO

File: vfo.sch

Sheet: Ant

File: ant.sch

Sheet: Tx

File: tx.sch

Sheet: Rx

File: rx.sch

Sheet: /
File: 40m-cw-transceiver.sch

Title: CW TRX by R2AUK ::: <https://eax.me/40m-qrp-transceiver/>

Size: A4 Date: 2020-10-29

Rev:

KiCad E.D.A. kicad (5.1.6-0-10_14)

Id: 1/6

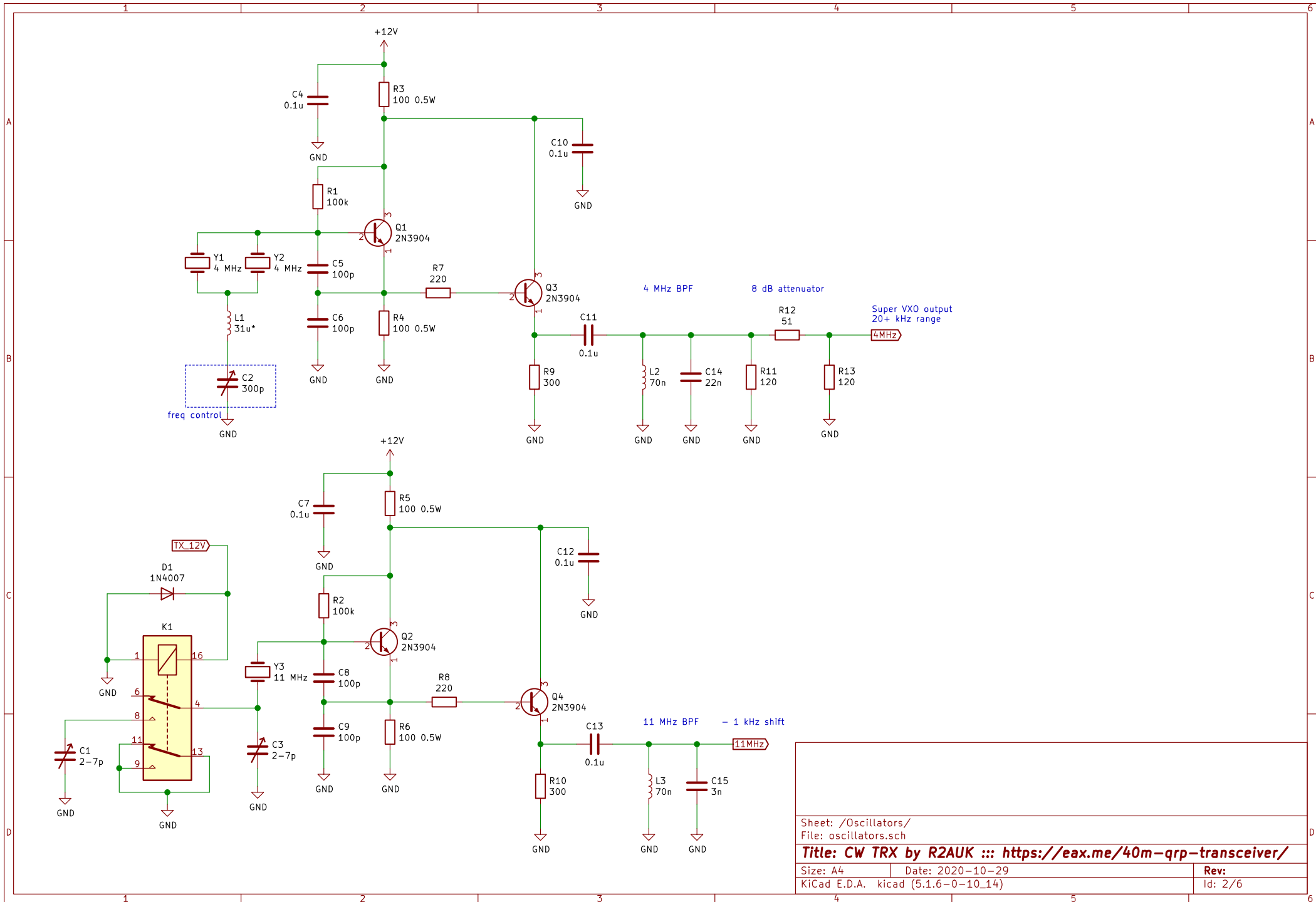

Sheet: /Oscillators/
File: oscillators.sch

Title: CW TRX by R2AUK :: <https://eax.me/40m-qrp-transceiver/>

Size: A4 Date: 2020-10-29

KiCad E.D.A. kicad (5.1.6-0-10_14)

Rev:

Id: 2/6

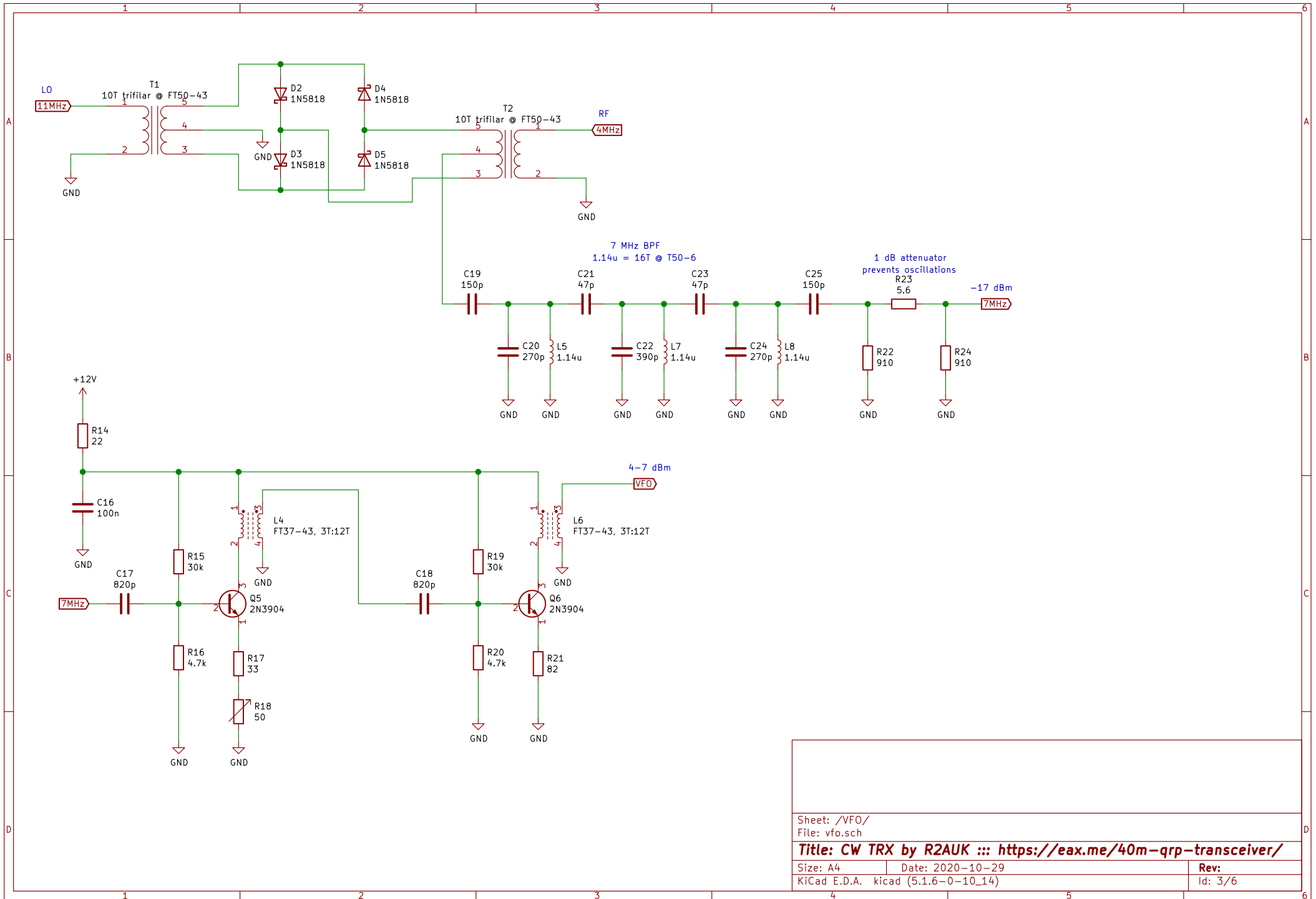

Sheet: /VFO/
 File: vfo.sch

Title: CW TRX by R2AUK ::: <https://eax.me/40m-qrp-transceiver/>

Size: A4 Date: 2020-10-29

KiCad E.D.A. kicad (5.1.6-0-10_14)

Rev:
 Id: 3/6

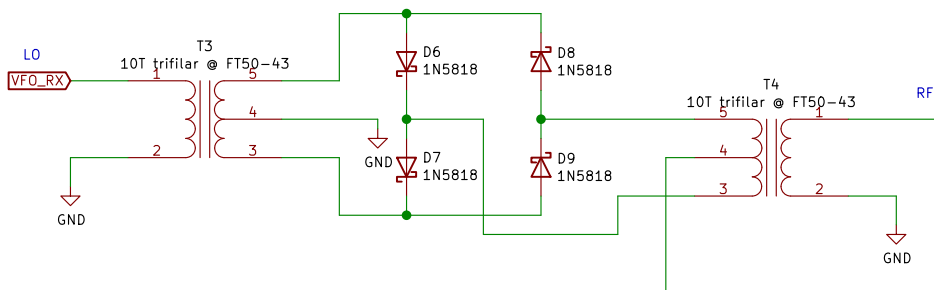
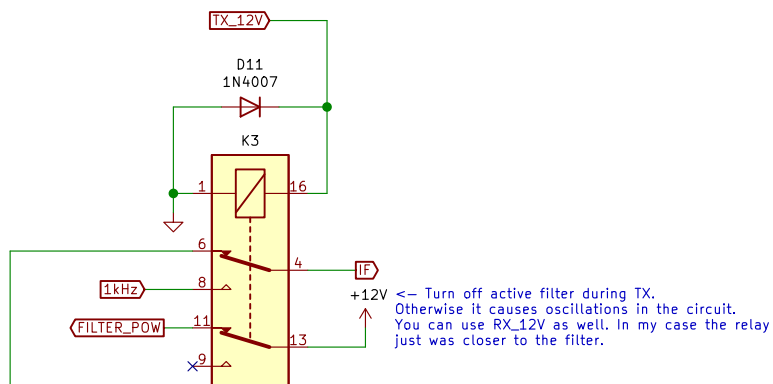
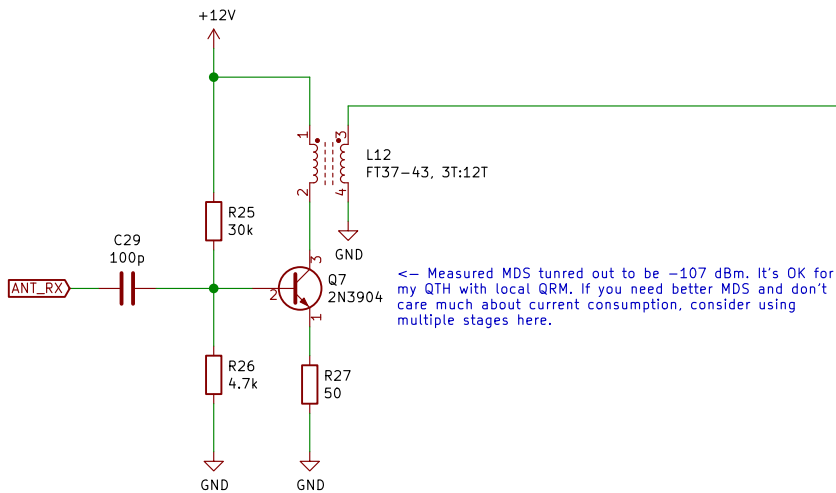
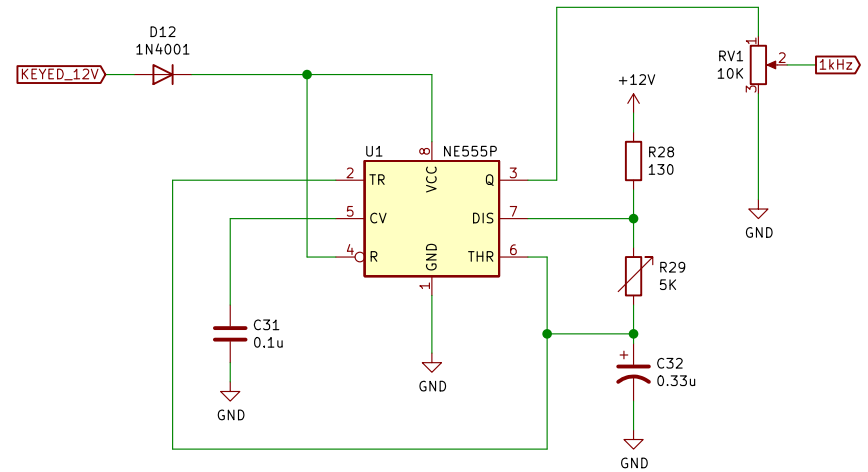
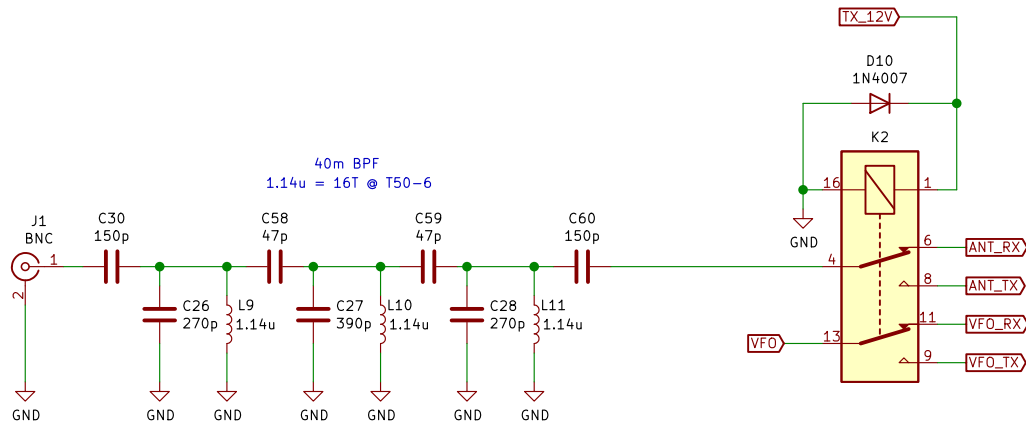

Sheet: /Ant/
File: ant.sch

Title: CW TRX by R2AUK ::: <https://eax.me/40m-qrp-transceiver/>

Size: A4 Date: 2020-10-29

KiCad E.D.A. kicad (5.1.6-0-10_14)

Rev:

Id: 4/6

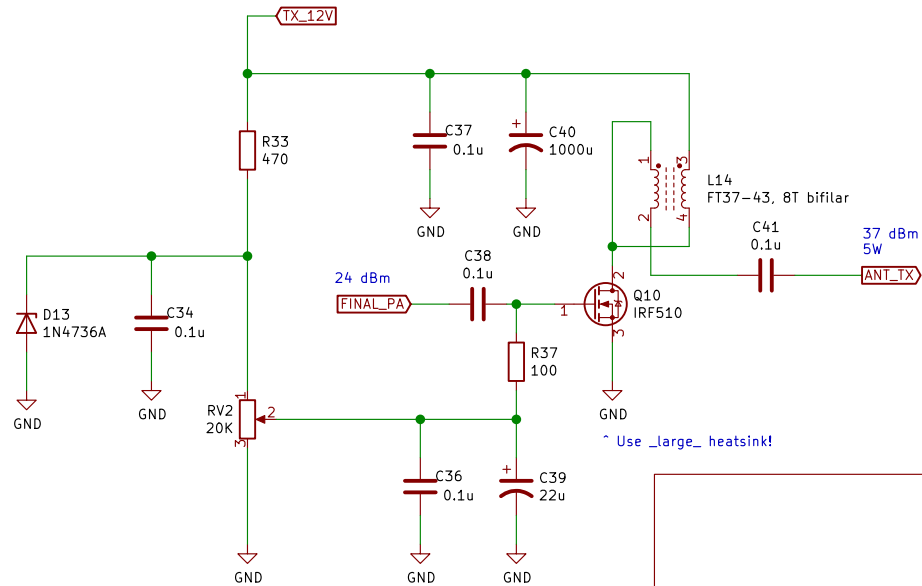
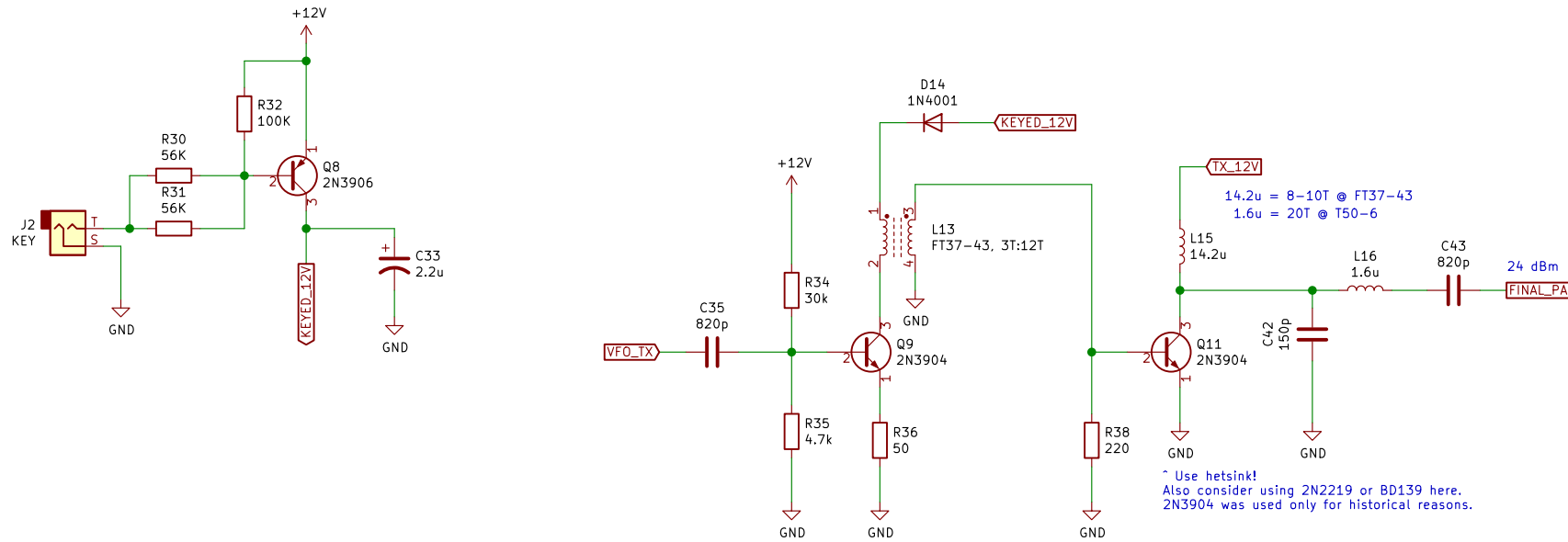

Sheet: /Tx/		Date: 2020-10-29	
File: tx.sch		Rev:	
Title: CW TRX by R2AUK ::: https://eax.me/40m-qrp-transceiver/			
Size: A4	KiCad E.D.A. kicad (5.1.6-0-10_14)		Id: 5/6

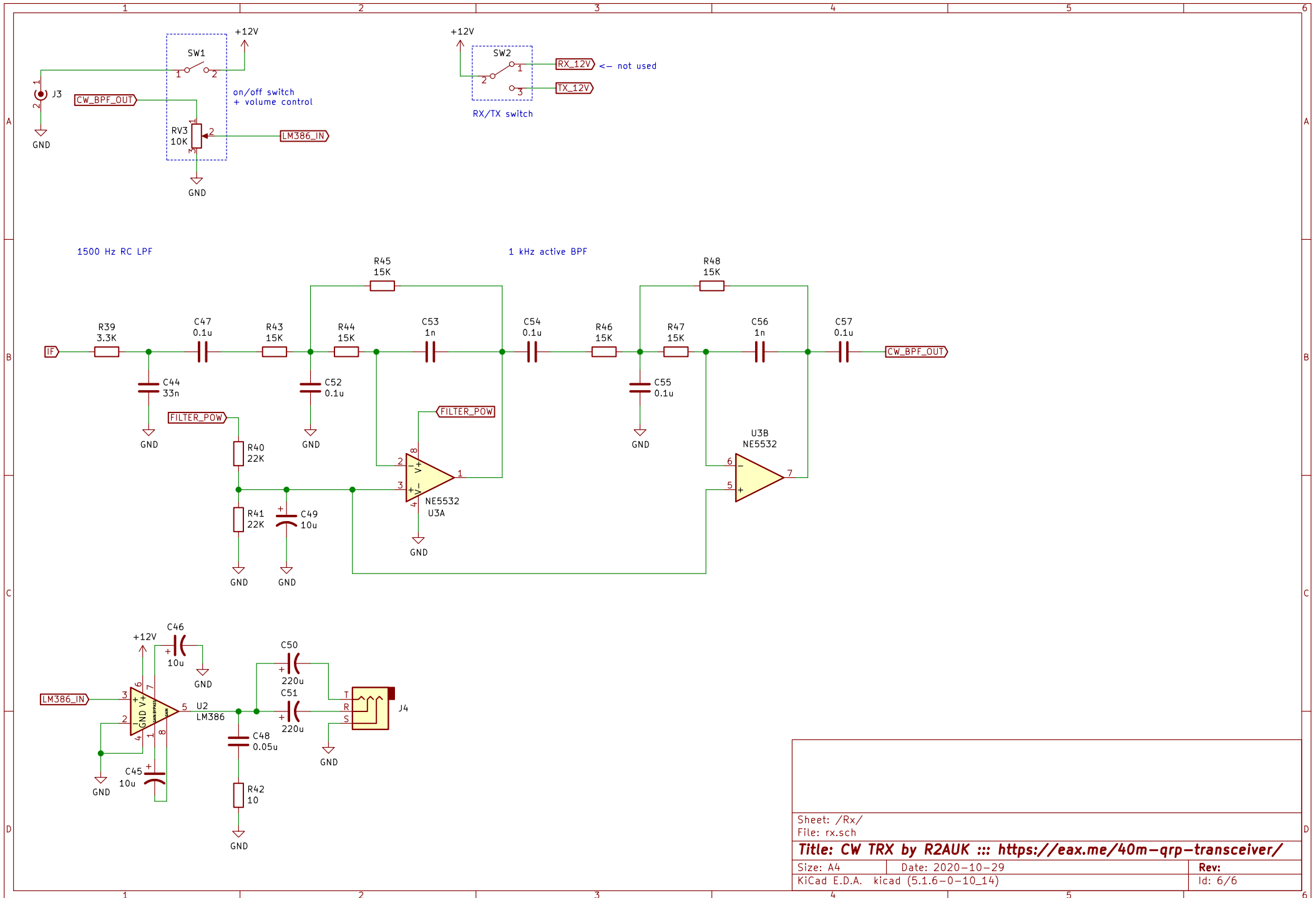

Sheet: /Rx/		File: rx.sch	
Title: CW TRX by R2AUK ::: https://eax.me/40m-qrp-transceiver/			
Size: A4	Date: 2020-10-29	Rev:	
KiCad E.D.A. kicad (5.1.6-0-10_14)	Id: 6/6		