

AF Amp

File: af-amp.kicad_sch

Mic Amp

File: mic-amp.kicad_sch

BFO

File: bfo.kicad_sch

IF

File: if.kicad_sch

RF

File: rf.kicad_sch

Power Amp

File: power-amp.kicad_sch

LPF

File: lpf.kicad_sch

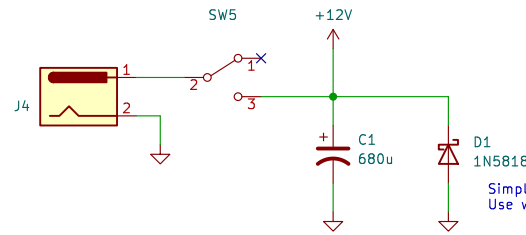
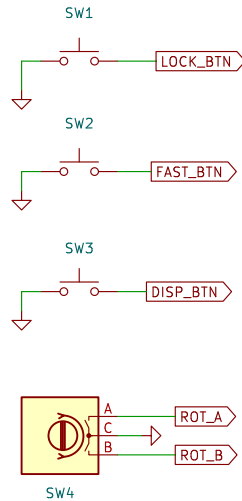

Simple reverse polarity protection. Use with an external 2A fuse.

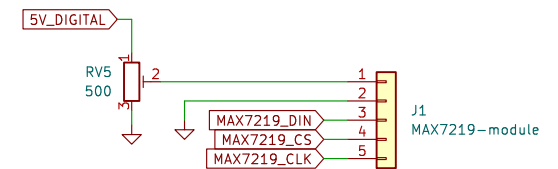
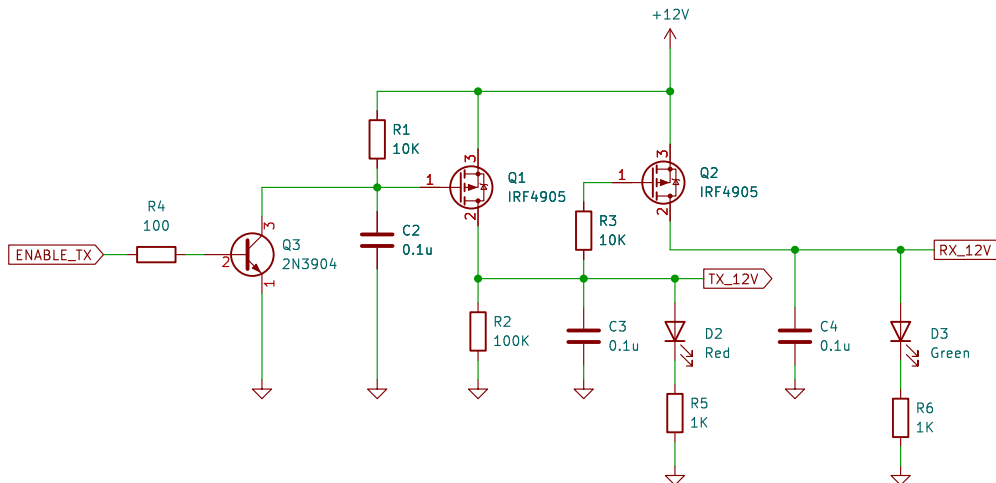
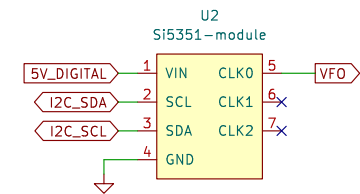
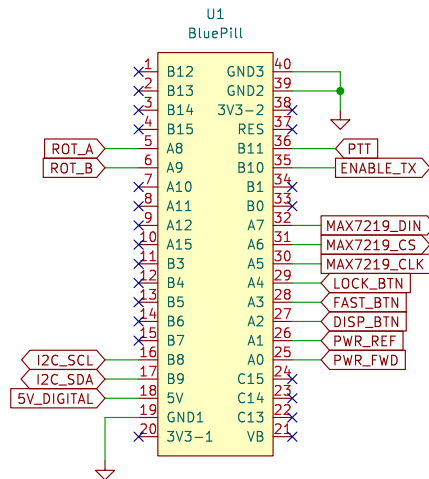
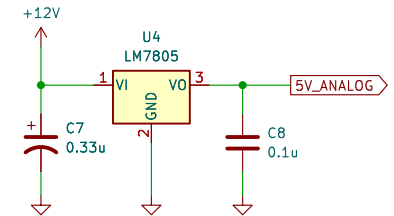
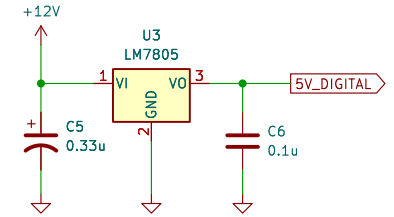

Turned out that MAX7219 generates noise that is picked up by the AF Amp. The noise can be moved below 20 Hz by reducing supply voltage. This reduces brightness but the information is still readable.

Sheet: /		File: hbr-40.kicad_sch	
Title: HBR/40 by R2AUK ::: https://eax.me/hbr-40-transceiver/			
Size: A4	Date: 2023-09-03	Rev:	
KiCad E.D.A. kicad 7.0.5-0	Id: 1/8		

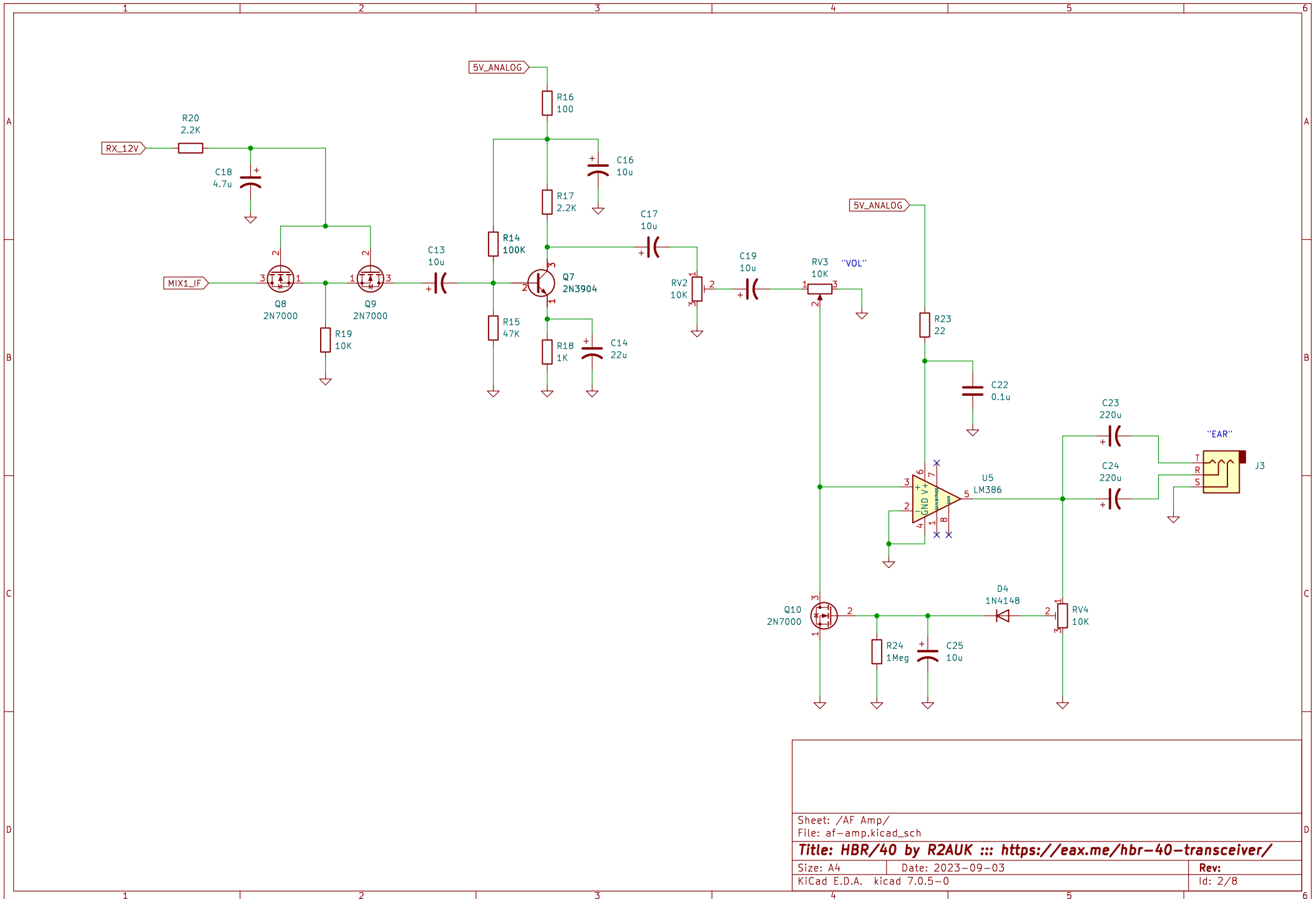

Sheet: /AF Amp/
 File: af-amp.kicad_sch
Title: HBR/40 by R2AUK ::: <https://eax.me/hbr-40-transceiver/>
 Size: A4 | Date: 2023-09-03 | Rev:
 KiCad E.D.A. kicad 7.0.5-0 | Id: 2/8

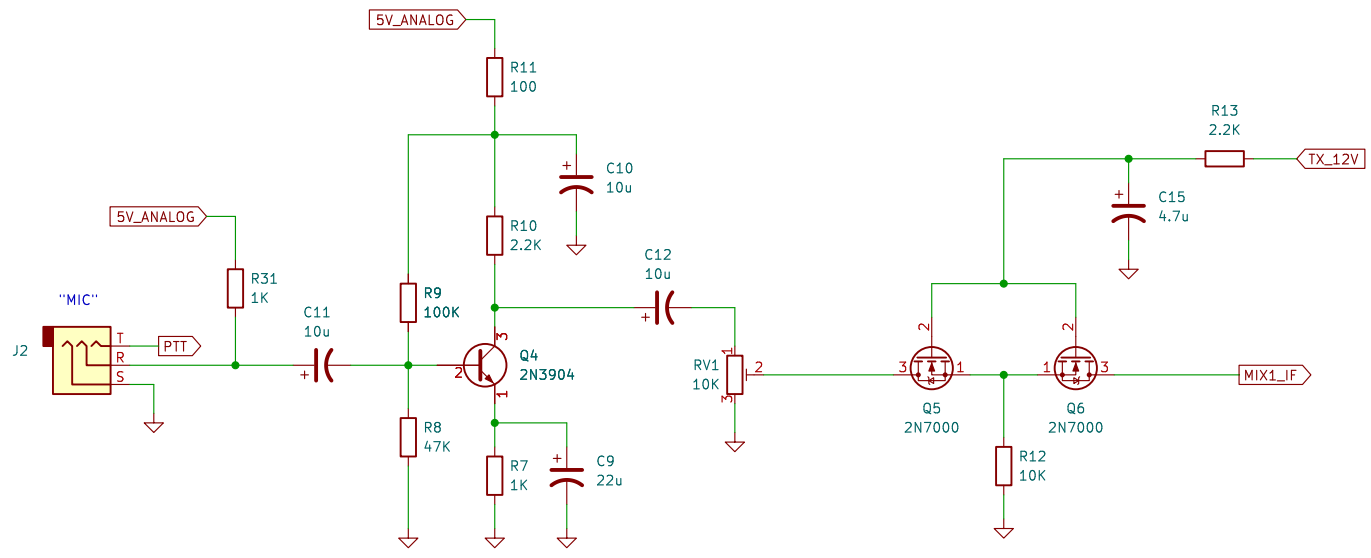

Sheet: /Mic Amp/	
File: mic-amp.kicad_sch	
Title: HBR/40 by R2AUK ::: https://eax.me/hbr-40-transceiver/	
Size: A4	Date: 2023-09-03
KiCad E.D.A. kicad 7.0.5-0	Rev: Id: 3/8

Tune approximately to the crystal filter
center frequency minus 1.5 KHz

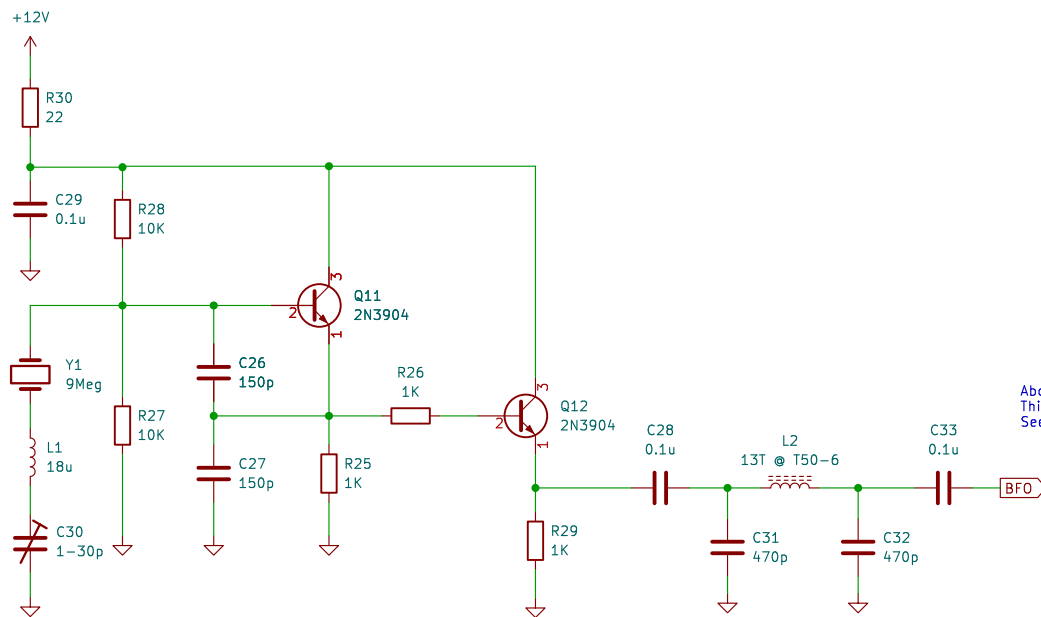

About 4 dBm to 50 Ohm
This is enough for SBL-1
See the datasheet

12 MHz LPF

Sheet: /BFO/

File: bfo.kicad_sch

Title: HBR/40 by R2AUK ::: <https://eax.me/hbr-40-transceiver/>

Size: A4 Date: 2023-09-03

KiCad E.D.A. kicad 7.0.5-0

Rev:

Id: 4/8

TIA == Termination Insensitive Amplifier
 See http://w7zoi.net/bidirectional_matched_amplifier.pdf
 Or alternatively <https://eax.me/bidirectional-power-amplifier/>

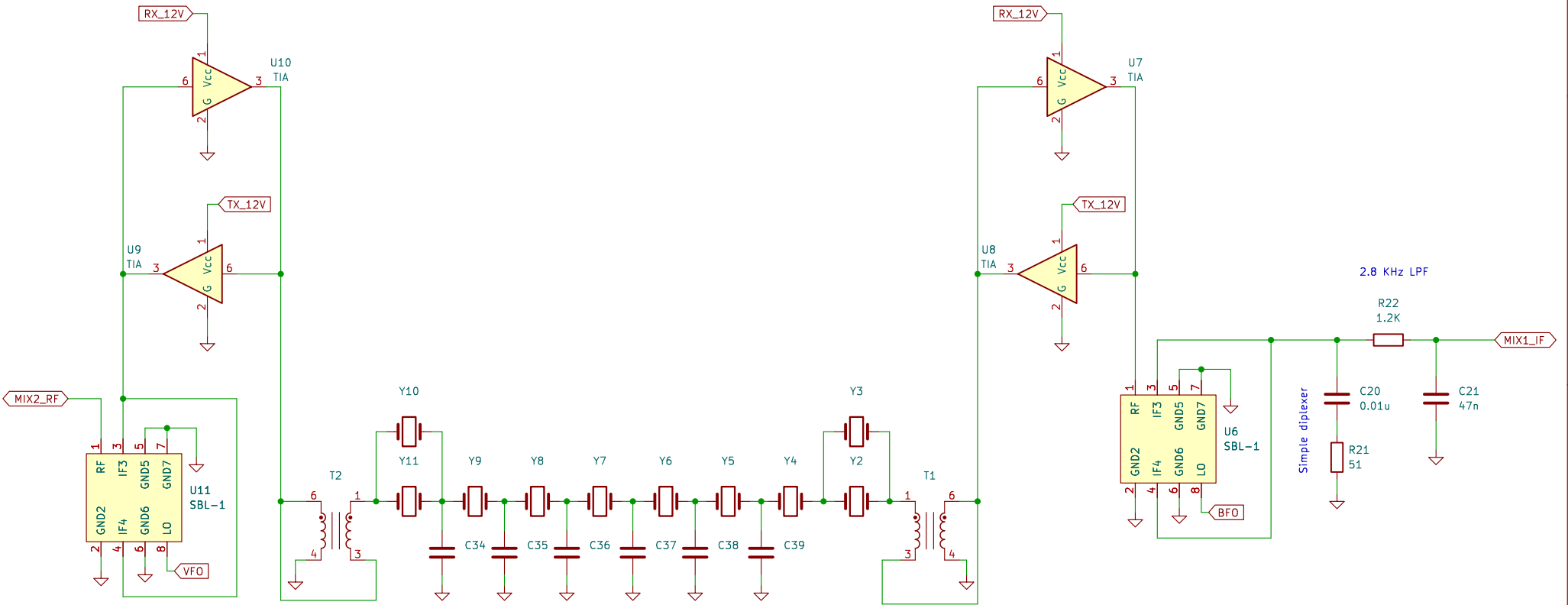

All crystals are 9 Mhz
 All capacitors are 56 or 68 pF
 Transformers are 10T bifilar @ FT37-43
 See <https://eax.me/crystal-filters-part-4/>

Sheet: /IF/
 File: if.kicad_sch

Title: HBR/40 by R2AUK ::: <https://eax.me/hbr-40-transceiver/>

Size: A4 Date: 2023-09-03

KiCad E.D.A. kicad 7.0.5-0

Rev:

Id: 5/8

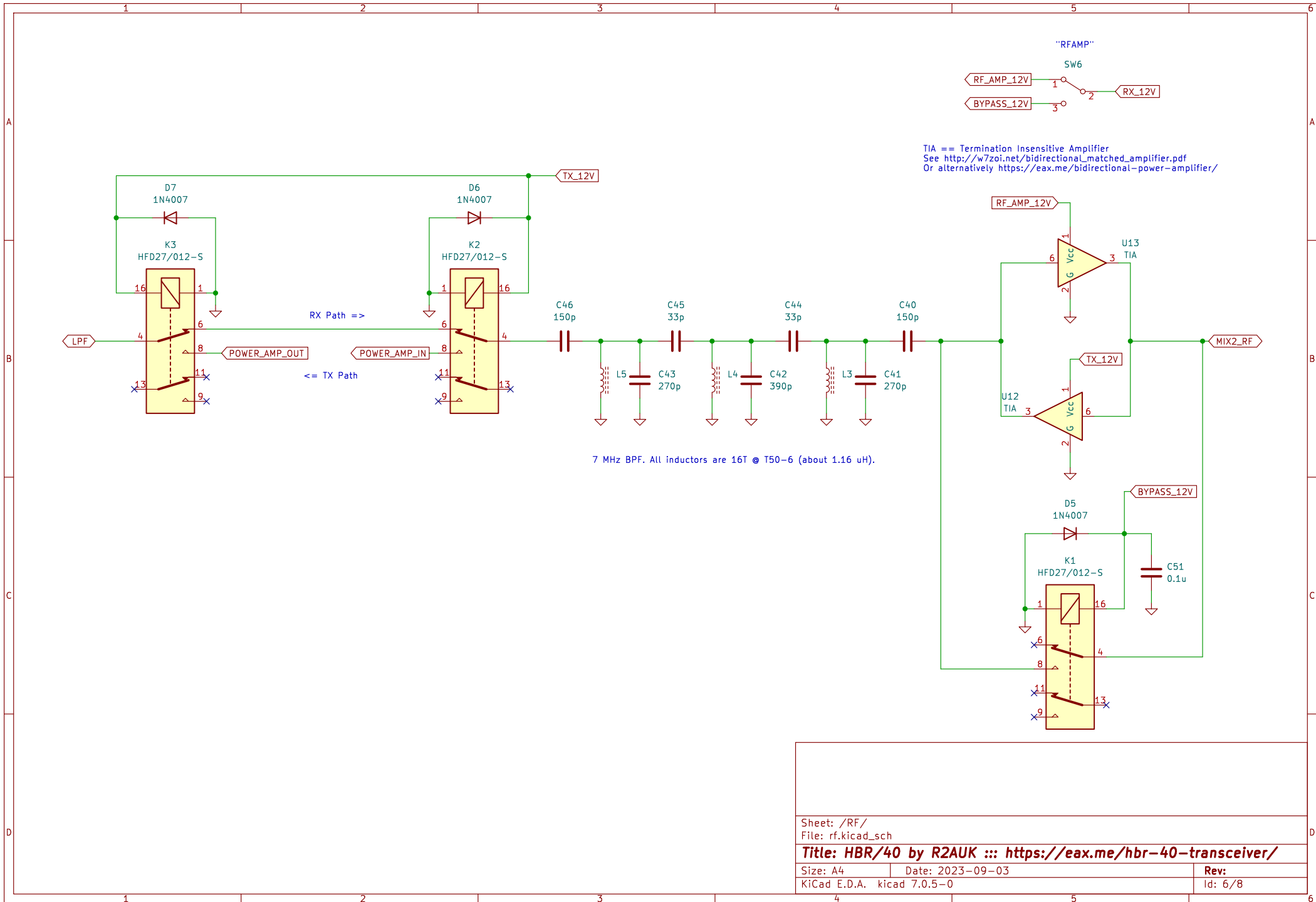

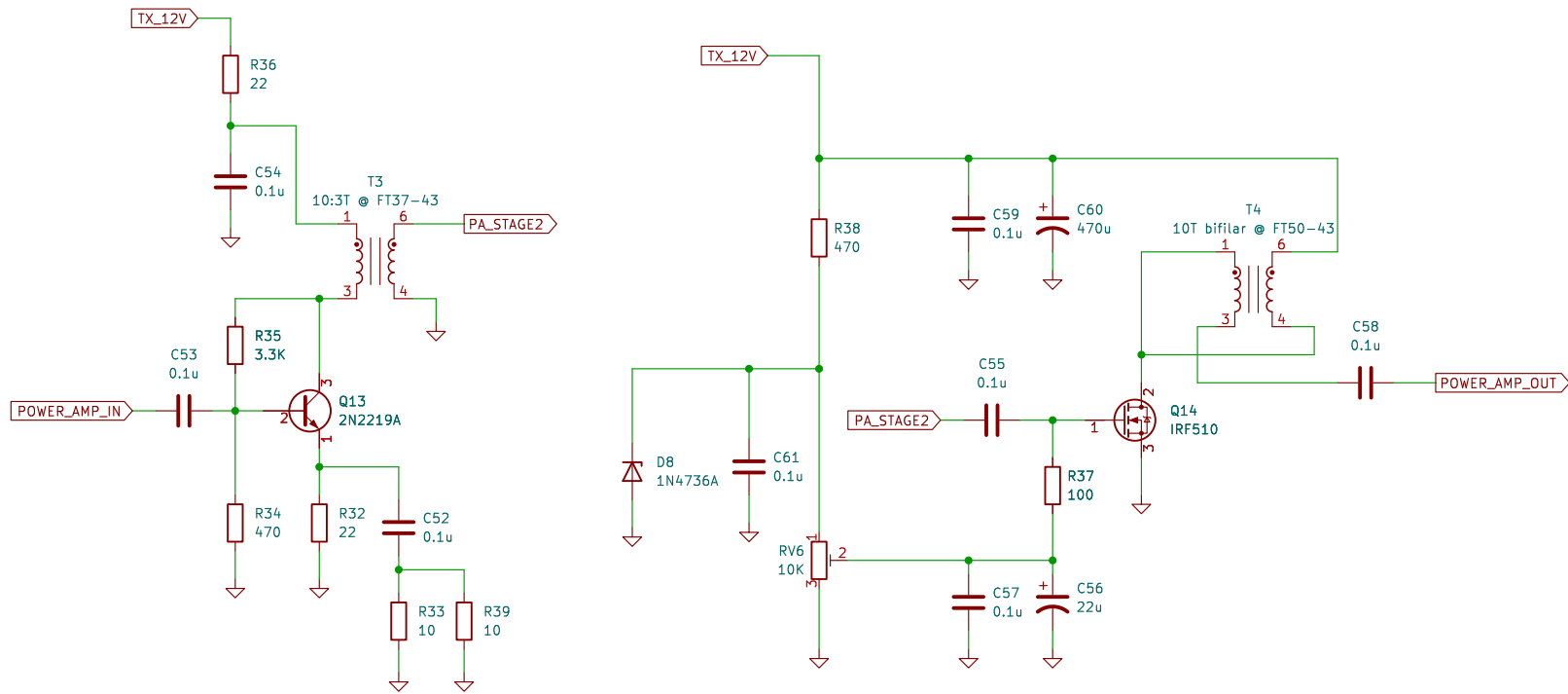

Sheet: /Power Amp/		Date: 2023-09-03	
File: power-amp.kicad_sch		Rev:	
Title: HBR/40 by R2AUK :: https://eax.me/hbr-40-transceiver/			
Size: A4	KiCad E.D.A. kicad 7.0.5-0		Id: 7/8

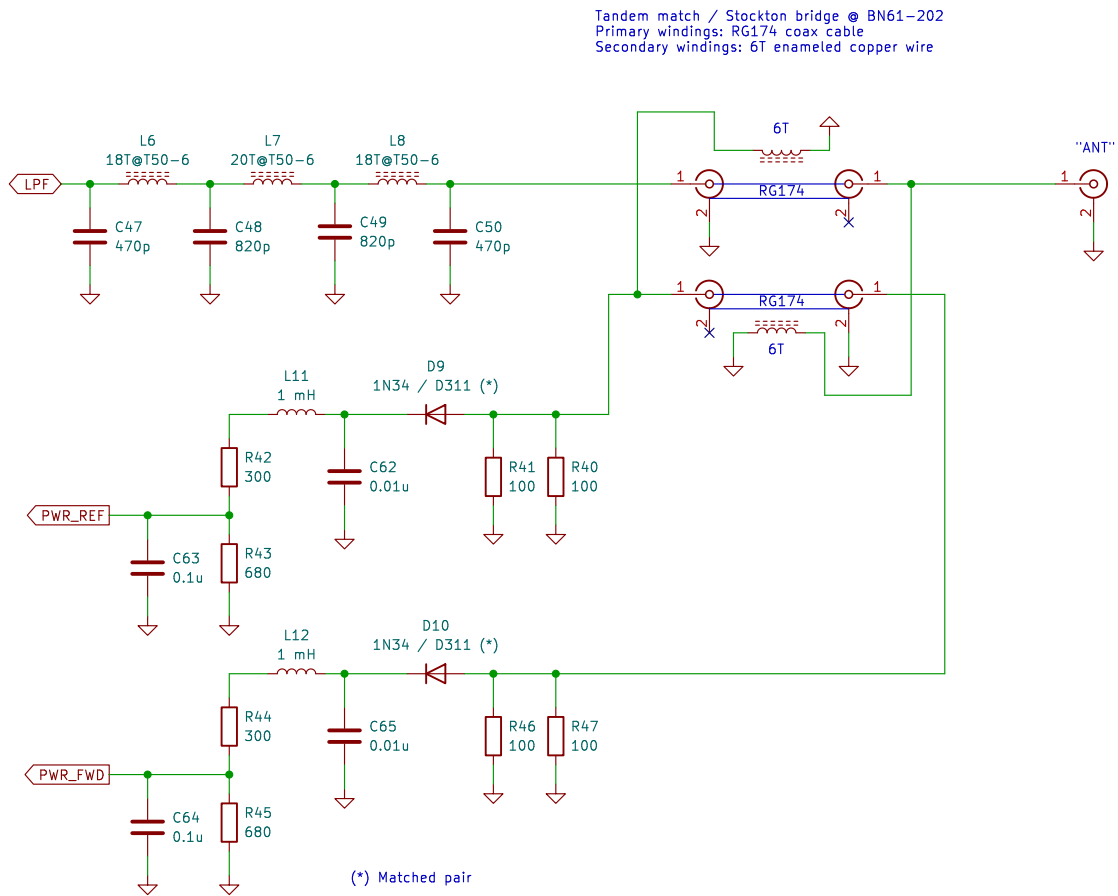

Sheet: /LPF/		Date: 2023-09-03	
File: lpf.kicad_sch		Rev:	
Title: HBR/40 by R2AUK :: https://eax.me/hbr-40-transceiver/			
Size: A4	KiCad E.D.A. kicad 7.0.5-0		Id: 8/8